

Storage and Handling of APA Trademarked Panels

To assure optimum performance, APA trademarked wood structural panels must be stored and handled properly. Adhering to the panel producer's recommendations or the following guidelines will help protect panels from damage in storage, during shipment, and on the job site.

Handling in Transit. Take precautions to protect panel ends and edges during shipment, especially with tongue-and-groove and shiplap-edged products.

If panels are shipped on open truckbeds, cover them with a tarp. For open railcar shipment, use lumber wrap to keep panels dry and clean.

Storage in the Yard and on the Job Site. Whenever possible, store panels under a roof. Keep sanded panels and appearance-grade products away from high traffic areas to prevent damage to surfaces. Use pieces of lumber to weight down the top panel in a stack to reduce warpage from humidity. If moisture absorption is expected, cut steel bands on bundles to prevent edge damage.

Outside Storage. If panels must be stored outside, stack them on a level platform supported by at least three 4x4s to keep them off the ground. Place one 4x4 in the center and the other two 12 to 16 inches from the ends. Never leave panels or the platform in direct contact with the ground.

Cover the stack loosely with plastic sheets or tarps. Anchor the covering at the top of the stack, but keep it open and away from the sides and bottom to ensure good ventilation. Tight coverings prevent air circulation and when exposed to sunlight, may promote mold or mildew.

STORAGE TIP

Build platform of cull panel and scrap lumber 4x4s for stacking panels.

Stretch plastic film over platform to block passage of ground moisture.

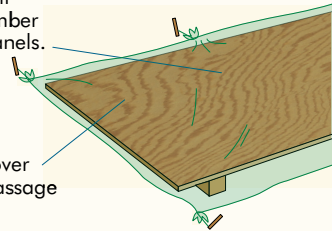

STORAGE TIP

Nail film to top panel and drape over ends for protection against driving rain. Weight lower end with 2x4.

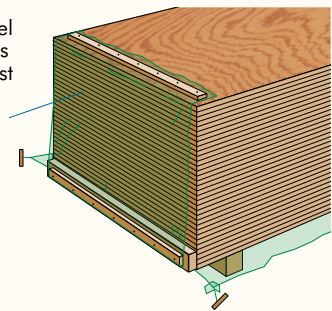

OUTSIDE STORAGE TIP

Pad corners with rags.

Lay two 2x4s on top of stack.

Stretch film over stack and secure to tie-down stakes.

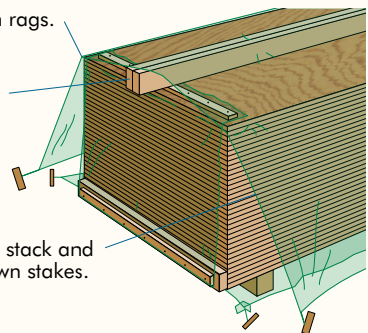

We have field representatives in many major U.S. cities and in Canada who can help answer questions involving APA trademarked products. For additional assistance in specifying engineered wood products, contact us:

APA HEADQUARTERS: 7011 So. 19th St. ■ Tacoma, Washington 98466 ■ (253) 565-6600 ■ Fax: (253) 565-7265

APA PRODUCT SUPPORT HELP DESK: (253) 620-7400 ■ E-mail: help@apawood.org

Form No. U450G

Revised May 2013

DISCLAIMER: *The information contained herein is based on APA – The Engineered Wood Association’s continuing programs of laboratory testing, product research, and comprehensive field experience. Neither APA, nor its members make any warranty, expressed or implied, or assume any legal liability or responsibility for the use, application of, and/or reference to opinions, findings, conclusions, or recommendations included in this publication. Consult your local jurisdiction or design professional to assure compliance with code, construction, and performance requirements. Because APA has no control over quality of workmanship or the conditions under which engineered wood products are used, it cannot accept responsibility for product performance or designs as actually constructed.*



REPRESENTING THE ENGINEERED WOOD INDUSTRY